



Constant-pressure regulator

Size 3

737.601 to 737.705

G 3/4 (red.)

G 1

- 0.5 to 3 bar
- 0.5 to 6 bar
- 0.5 to 10 bar
- 0.5 to 16 bar
- 0.5 to 25 bar

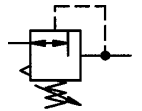

Characteristics

Order No.	737.701	737.702	737.703	737.704	737.705
Port	G 1				
Order No.	737.601	737.602	737.603	737.604	737.605
Port	G 3/4 (reduced)				
Pressure gauge port	G 1/4				
Type of construction	Diaphragm pressure regulator with self-relieving design				
	Special versions on request e.g. - Reverse flow port closed				
Max. input pressure p ₁	40 bar				
Control range p ₂	0.5 to 3 bar / 0.5 to 6 bar / 0.5 to 10 bar / 0.5 to 16 bar / 0.5 to 25 bar				
Mounting position	Any / note direction of arrow				
Mounting type	Bracket				
Medium temperature	-10 °C to 60 °C				
Ambient temperature	-10 °C to 90 °C				
Weight [g]	3500 / 3650 with pressure gauge				

Description

- Standard design
- Conical double nipples (G 1) required for block mounting with other devices
- Pressure setting until 10 bar by adjusting screw with T-handle, 16 + 25 bar by hexagon screw a/f 19; setting can be locked with lock nut
- Flow direction indicated by arrows
- **Entry in direction of arrow**
- Working pressure remains virtually **constant, regardless** of system pressure fluctuations and air consumption
- Pressure gauge Ø 63 included, can be mounted at both ends
- Wall mounting with mounting bracket on cover
- Max. output pressure **25 bar**

Materials

Part	Material
Head piece (body)	Brass
Spring bonnet/adjusting screw	Brass
Diaphragm →	NBR-brass
Pressure spring	Galvanised steel
Valve cone →	NBR-brass
Counter-pressure spring	Stainless steel
O-ring 34 x 3 →	NBR

Accessories

Designation	Order No.
Mounting bracket with 2 screws	H 88 252.07/2
Double nipple G 1 (R 1 conical) for block mounting with other devices	252.305
Reducing nipple G 1 male to G 3/4 female	MS251K134

Main spare parts

Part	Part No.
→ Set of wearing parts - Diaphragm, compl. - Valve cone, compl. - O-ring 34 x 3	22.773.4
Pr. gauge Ø 63, G 1/4	
0 to 4 bar	215-KD
0 to 6 bar	216-KD
0 to 10 bar	217-KD
0 to 16 bar	218-KD
0 to 25 bar	219

Dimensions

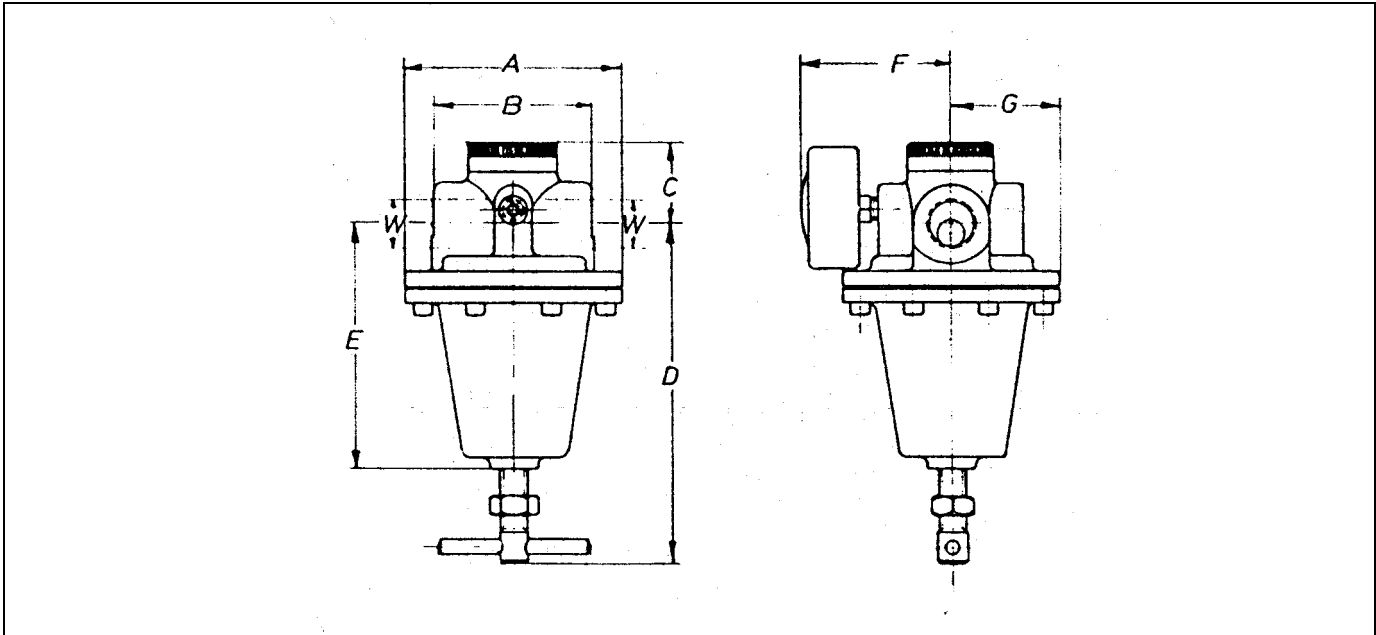

Dimensions [mm]

Art. No.	Dimensions								Rotary switch \varnothing	hexagon a/f	Pr. gauge \varnothing	
	A	B	C	D	E	F	G	G 1/4			63	
737.601 to 737.603	116.0	93.0	41.0	177.0	126.6	76.0	57.0	80	-	G 1/4	63	
737.701 and 737.703	116.0	81.0	43.0	177.0	126.6	76.0	57.0	80	-	-	-	
737.604 to 737.605	116.0	93.0	43.0	172.0	126.6	76.0	57.0	-	19	G 1/4	63	
737.704 and 737.705	116.0	81.0	43.0	172.0	126.6	76.0	57.0	-	19	-	-	

Flow rates

Flow rates at $p_1 > p_2 + 2$ bar / G 1 port

Art. No.	QN m^3/h QN l/min	737.601	737.602	737.603	737.604	737.605
		737.701	737.702	737.703	737.704	737.705
Output pressure $p_2 = 6$ [bar]		522	492	470	444	390
Nominal flow ($\Delta p < 1$ bar)		8700	8200	7830	7400	6500

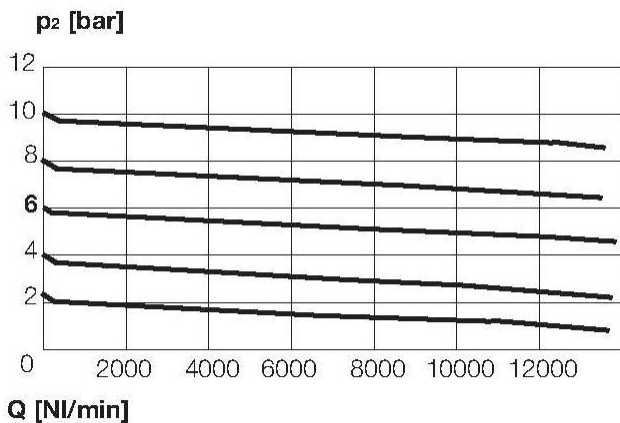

© Riegler 2-14